



EXPLORER®

Analytical, Precision, and High Capacity Balances



Flagship Balances from OHAUS

The OHAUS Explorer Series of analytical balances combine modern features and design elements to offer unmatched functionality in a line of high-performance balances unlike any other on the market. These smart and intuitive balances and all of their intelligent features simplify even the most complex laboratory measurements.

Unique Features Include:

- Equipped with a weighing cell that's precision-machined from a solid metal block, Explorer balances are extremely accurate and durable, and are ideal for laboratory and industrial environments.
- Features such as four-level user management with password protection, and un-editable system log plus a high level of configurability make Explorer balances well suited for regulated applications.
- A detachable terminal with a large color touchscreen, programmable IR sensors, automatic doors, and a frameless draftshield make Explorer analytical balances easy and convenient to use.

EXPLORER® Analytical, Precision, and High Capacity Balances

Intelligent. Intuitive. Ingeniously Practical.

The OHAUS Explorer Series of analytical, precision and high-capacity balances are capable of meeting the needs of your customers' laboratory and industrial applications. Explorer balances are able to increase operational efficiency by offering features such as a large color touch screen and intuitive user interface, large weighing pans, multiple connectivity options, and 14 weighing applications. They are durably constructed and offer capacities up to 35kg, readabilities from 0.1mg to 0.1g, and provide exceptional weighing performance for applications requiring high accuracy and repeatability.

Weighing Performance

OHAUS' signature AutoCal™ internal calibration system ensures the balance is always ready for use. It eliminates the need for manual routine calibration and eliminates the need to maintain external calibration weights. Additionally a built in Repeatability Test helps evaluate the balance's performance and aids in determining a suitable minimum weight for applications requiring high accuracy.

Connectivity

Explorer balances provide a variety of communication interfaces such as RS-232, USB, and Ethernet, allowing accessories such as RFID readers, impact printers, label printers and barcode scanners to be connected to the balance. A simple yet complete communication protocol allows Explorer balances to be easily connected to a PC or integrated with larger systems.

Data Management

Explorer balances are equipped with internal databases which can be used to store, manage, and retrieve application and system data. An internal weighing mode library allows saving and loading of weighing mode configurations. Explorer balances offer two types of log files. One is the system log file which records up to 5000 changes to the balance's settings, calibrations and adjustments, and user access. The other is the calibration log which tells you when last calibrated the balance. Both log files can be exported as a non-editable PDF file and saved onto a USB memory stick. A built-in real time clock ensures that the data captured is contemporaneous.

User Management

A simple yet effective user management system allows a system administrator to create up to 110 users and assign them to 1 of 4 pre-existing groups with varying access rights to the balance and enforce password policies. This provides security and allows Explorer balances to be used in multi-user workplaces and ensures that non-authorized users cannot change the balance's setup.

Intuitive efficient Operation

Explorer balances are easy to setup and use. They feature a large color graphic touch screen and intuitive user interface and can operate in 14 different languages. Additional features such as a detachable terminal and multiple programmable touchless sensors allow the user to initiate balance functions such as zero, tare, print, automatically open draftshield doors*, and more.

*(on models equipped with motorized draftshield doors only)



User Profiles			
#	User Name	Group	Password
>> 1	Admin	Administrator	
2	Jeremy	Supervisor	*****
3	Jonny	Operator	*****
4	Adam	Log Viewer	*****

Buttons: New, Edit, Delete, Return to Application

Ingenious DRAFTSHIELD

Explorer's draftshield provides ample access and visibility to the weighing chamber through the versatile top door and side sliding doors. Select models feature motorized side doors that open and close automatically with use of the touchless sensors on the base and display.

- The automatic draftshield door models have a new function for automatically opening draftshield doors without touching the balance. It helps to eliminate sample residue transfer and contaminations.
- Side doors seamlessly glide on top-mounted bearings
- The versatile top door offers two entry options; access the weighing chamber by flipping the top door or sliding the glass panel open.
- The expansive side entry 6.3" × 9.4" (160 mm × 240 mm) allows you to freely place and remove large weigh boats or other large vessels in the weighing chamber
- Antistatic coated glass helps dissipate static charges in the weighing chamber which could adversely affect the weighing results
- Easy to install and remove glass panels and a stainless steel bottom make Explorer extremely easy to clean
- A draftshield chamber light is available when the balance is used in low lighting environments



Practical TOUCHLESS SENSORS

Explorer features up to four touchless sensors for hands-free operation of zero, print, calibration, tare, automated draftshield doors and other selectable functions

- **Hands-free operation**
 - Improves weighing efficiency
 - Eliminates sample residue transfer
 - Minimizes contamination
- Two sensors on the base* and two on the display can be set up individually to allow for remote operations
- The sensors can be set up to provide automated operation of the draftshield side doors and can be programmed to automatically open the opposite side door in order to support efficient and logical sample placement with your free hand.



*Analytical and precision models only.

Automatic Draftshield door operation only offered on Analytical models

EXPLORER[®] Analytical, Precision, and High Capacity Balances

Intelligent CALIBRATION

AutoCal™ ensures performance and assists with routine maintenance by automatically calibrating the balance daily.

- Self-calibrates the system when it senses a temperature change sufficient enough to affect weighing accuracy, or every 3-11 hours, depending on the user configuration
- Performs routine calibration and reduces the need for external masses
- External Calibration Models Available —
Select models feature traditional external calibration in which external weights (user's choice of calibration weight values) are required to calibrate the balance to ensure accuracy

Intuitive USER SETUP

Explorer is the industry's most easy-to-use balance, featuring leveling assistance and instructional messaging for quick out-of-the-box setup and use.

- Easy to view illuminated level indicator placed at the front of the balance
- Adjustable thumbwheels are easy to turn to level the balance
- Level assist screen helps users quickly identify which thumbwheels need to be adjusted to level the balance
- Data Transfer Function helps to output data directly into Microsoft Excel
- Instructional messaging during application use guides users through the weighing process
- User information menu allows users quickly view and learn more about the available balances features
- Up to 14 operating languages make Explorer's Intuitive User Setup truly universal

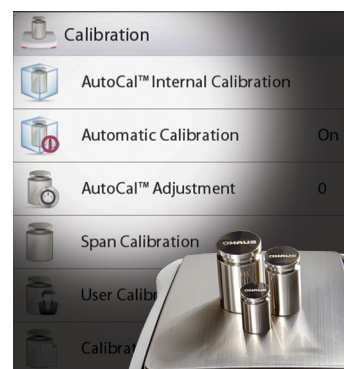

Dimensions

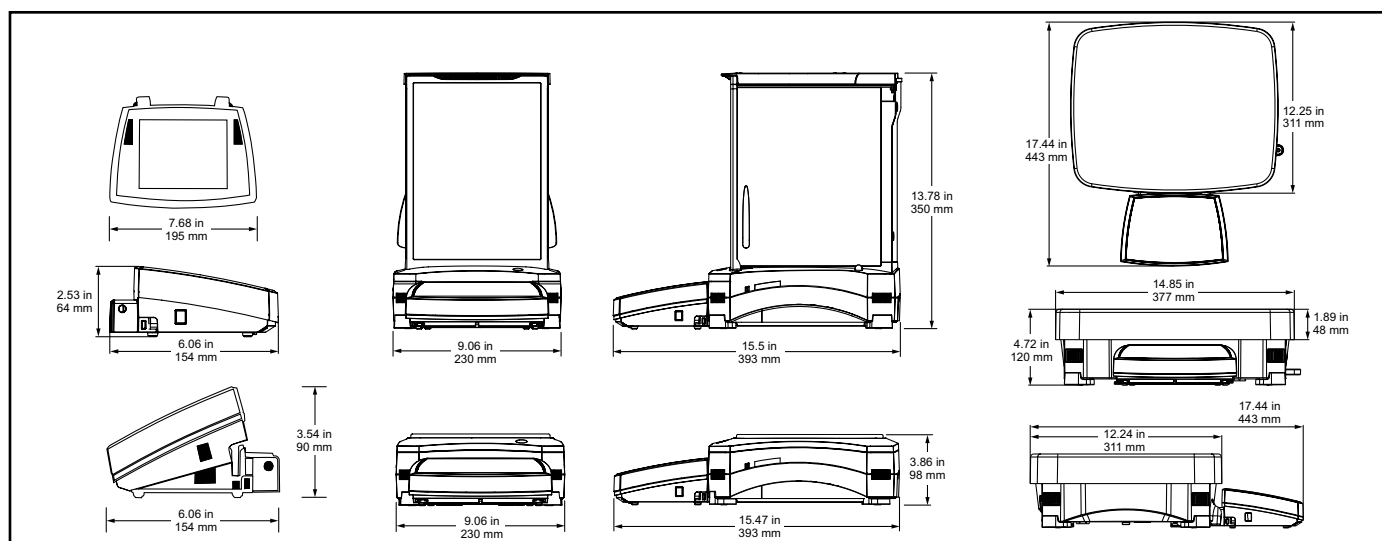

Ingenious MODULAR DESIGN

Explorer's modular design features a color touch display that can be separated from the weighing base

- **Display features:**

- 3 position, angular adjustment to optimize viewing
- Easy access communication ports include standard USB and RS232 and an optional third port for either RS232 or Ethernet
- Left and right side cable exit feature for customized installation capability
- Tower and wall mount ready for modular installation*
- In-use cover for protection against rugged use
- Extension cable accessory extends remote use up to 27 feet (9 meters)



- **Base features**

- Quadrastance™ design with four adjustable thumbwheels provides superior stability
- Robust die-cast metal bottom housing
- Accessory tower mount ready for modular installation
- Cable storage system underneath base keeps excess cables manageable

- **Adjustable rolling feet accessory allows for simple and quick movement and relocation of the balance****

*Tower mount sold separately

**High capacity models only



Practical APPROVALS

Explorer EX...N series of balances meet or exceed the Class I or II accuracy requirements in accordance with NIST Handbook 44 and Canada's Weights and Measures Regulations. Certificate of Conformance Number 12-012 was issued under the National Type Evaluation Program (NTEP) of the National Conference on Weights and Measures. Notice of Approval AM-5847 was issued by Measurement Canada, an Agency of Industry Canada.

Other Standard Features & Equipment:

Menu lock switch, security bracket, integral weigh below hook for below balance weighing applications, removable stainless steel weighing pan, stability indicator, overload and underload indicators, auto standby.



EXPLORER® Application Software

The OHAUS Explorer's advanced applications simplify even the most complex laboratory measurements. Whether it's determining the difference between initial and residual weights or calculating the density of solids and liquids,

Explorer eliminates the need for time consuming manual calculations and data logging. The high resolution display and innovative user interface make balance setup and application use effortless.

Displays your current application. One-touch drop down menu shows additional application choices

Touch to change your application settings

Quickly store and recall your library data of regularly used items

Need help? Just tap the Info button for built-in assistance

Easy-to-follow text prompts tell you what to do next

Large weigh results can be viewed at any angle

Results area shows pertinent application information (varies by application)

Seven quick keys make balance operation a breeze!



Battery life indicator when powered by optional battery pack (for High Capacity models only)

Press the weighing unit to change the unit of measure (activate in Weighing Units menu)

Fill and capacity bar indicators assure you are always in range (indicators vary by application)

Soft keys are application specific

Press Menu to choose applications, change user settings, balance setup and much more!

Standard Apps



Weighing

Determine weight of items in the selected unit of measure. Minimum Weight feature is also available.



Percent Weighing

Measure the weight of a sample displayed as a percentage of a pre-established Reference Weight.



Dynamic Weighing

Weigh an unstable load. Balance takes an average of weights over a time period.



Totalization

Measure cumulative weight of multiple items. Cumulative total may exceed balance capacity.



Fill Weight Variation

Check whether the individual pill weight is in the tolerance of the average of total pill weight



Differential Weighing

Store sample weights and calculate the difference between initial weights and final weights.



Peak Hold

Capture and store highest weight in a series. Both stable and unstable weights are captured.



Parts Counting

Count samples of uniform weight. Choose Standard Counting, Check Counting, or Fill Counting.



Pipette Adjustment

Check pipette values by weight analysis, with built-in water density table. (Non High Capacity Models)



Check Weighing

Compare the weight of a sample against target limits. Choose from Standard, Nominal-weight, or Nominal-Percent.



Filling

Fill a container to a target weight. Progress bar displays filling status.



Formulation

For compounding and recipe making. The number of components can be from two to 99.



Density Determination

Determine density of solids more dense than water, solids less dense than water, liquids, or porous material.



Ingredient Costing

Determine cost of formula or recipe based on known cost/quantity of components or ingredients.



SQC

Monitor and/or control processes to eliminate under and over filling.

EXPLORER® High Capacity

The Explorer series includes three high-capacity precision models with capacities up to 35 kg. Explorer high-capacity balances offer the same intuitive features, such as AutoCal™ and a 1 second stabilization time, with additional functions and attributes to support higher capacity weighing applications.

Modular Design

- 5.7" (145mm) diagonal color VGA touch screen optimizes viewing and menu navigation
- Two touchless sensors on display offer hands-free operation
- The display can be separated from the base up to 5 feet (1.5 meters) in order to fit operational needs in almost any workspace. A 27 foot (9 meter) cable is also available when additional flexibility is needed.

Superior protection in rugged or unstable environments

- With a die-cast metal base and a 14.8" × 12.2" (377 × 311 mm) stainless steel pan, the Explorer High Capacity is built to withstand rugged, every day use.
- 2-D Protection prevents shock and damage associated with movement and forces applied to the balance
- IP54 base enclosure protects the weighing base from damage by debris, humidity and accidental spills and splashes. (High Capacity models only)

High Capacity Accessories for Added Efficiency

- Adjustable rolling feet option provides assistance to easily moving the balance
- Rechargeable battery option provides 10 hours of operation away from a power source
- Weigh-below hook included and can be used for density determination



Shown with optional tower mount and rolling feet

Model	EX12001	EX24001	EX35001
Approved Model	EX12001M	EX24001M	EX35001M
Capacity (g)	12000	24000	35000
Readability (g)	0.1	0.1	0.1
Verification Interval, Approved Models	1	1	1
Class, Approved Models	II	II	II
Repeatability (sd.), ≤5% of Full Load (g)	0.08		
Repeatability (sd.), 5% of Full Load to Full Range (g)	0.1		
Linearity Deviation, Typical (g)	±0.06		
Linearity Deviation (g)	±0.2		
Stabilization Time (s)	≤1		
Sensitivity Draft (PPM/°C)	3		
Min-Weight (Typical) (g) (USP, K=2, U=0.10%)	160		
Min-Weight (Optimal) (g) (USP, K=2, U=0.10%, SRP≤0.41d)***	82		
Min-Weight (Typical) (g) (USP, K=2, U=1%)	16		
Weighing Applications	Weighing, Percent Weighing, Parts Counting, Check Weighing, Dynamic/Animal Weighing, Filling, Totalization, Formulation, Differential Weighing, Density Determination, Peak Hold, Ingredient Costing, SQC, Fill Weight Variation		
Weighing Units	g, kg, ct, gn, lb, oz, ozt, N, dwt, hkt, sgt, twt, mom, tical, msg, tola, Custom Unit 1, Custom Unit 2, Custom Unit 3		
Weighing Units, Approved Models	g, kg, ct		
Pan Size (mm)	377 × 311		
Calibration	AutoCal™ internal calibration		
Tare Range	To capacity by subtraction		
Power Requirement	Power Input 100-240 VAC 0.5-0.25A 47-63 Hz, Power Output: 24 VDC, 0.63 A, 15W		
Display Type	Full-color VGA graphic display, 4-wire resistive touch screen		
Display Size	145 mm (diagonal)		
Display Housing (W × H × D)	195 × 90 × 154 mm		
Base Housing (W × H × D)	377 × 120 × 443 mm		
Communication	Standard RS232, USB, Optional Ethernet		
Operating Temperature Range	10°C to 30°C		
Operating Humidity Range	15% to 80% at 30°C, decreasing linearly to 50% at 40°C, non-condensing		
Storage Conditions	-10°C to 60°C at 10% to 90% relative humidity, non-condensing		
Net Weight	10 kg		
Shipping Weight	12.5 kg		
Shipping Dimensions	665 × 525 × 330 mm		

EXPLORER[®] Analytical and Precision Balances

Model	EX124	EX224	EX324	EX223	EX423	EX623	EX1103	EX2202	EX4202	EX6202	EX10202	EX6201	EX10201
Automatic Door	EX124/AD	EX224/AD	EX324/AD	—	—	—	—	—	—	—	—	—	—
External Calibration	—	—	—	EX223/E	EX423/E	—	—	EX2202/E	EX4202/E	EX6202/E	—	EX6201/E	—
Approved Model	—	EX224M EX224M/AD	EX324M EX324M/AD	—	EX423M	—	EX1103M	—	EX4202M	—	EX10202M	—	EX10201M
Capacity (g)	120	220	320	220	420	620	1100	2200	4200	6200	10200	6200	10200
Readability (g)	0.0001			0.001			0.01			0.1			
Verification Interval, Approved Models	—	1mg		—	0.01g	—	0.01g	—	0.1g	—	0.1g	—	0.1g
Class, Approved Models	—	I		—	II	—	I	—	II	—	I	—	I
Repeatability (sd.), ≤5% of Full Load (g)	0.00008			0.0008			0.008			0.08			
Repeatability (sd.), 5% of Full Load to Full Range (g)	0.0001			0.001			0.01			0.1			
Linearity Deviation, Typical (g)	±0.00006			±0.0006			±0.006			±0.06			
Linearity Deviation (g)	±0.0002			±0.002			±0.02			±0.2			
Stabilization Time (sec)	≤2		≤3	≤1.5			≤1						
Sensitivity Drift (ppm/°C)	1.5			3			5			3			
Min-Weight (Typical) (g) (USP, K=2, U=0.10%)	0.16			1.6			16			160			
Min-Weight (Optimal) (g) (USP, K=2, U=0.10%, SRP≤0.41d)***	0.082			0.82			8.2			82			
Min-Weight (Typical) (g) (USP, K=2, U=1%)	0.016			0.16			1.6			16			
Weighing Applications	Weighing, Percent Weighing, Parts Counting, Check Weighing, Dynamic/Animal Weighing, Filling, Totalization, Formulation, Differential Weighing, Density Determination, Peak Hold, Ingredient Costing, Pipette Adjustment, SQC, Fill Weight Variation												
Weighing Units	Gram, Milligram, Kilogram, Carat, Ounce, Ounce Troy, Pound, Pennyweight, Grain, Newton, Momme, Mesghal, Hong Kong Tael, Singapore Tael, Taiwan Tael, Tical, Tola, Baht, Custom Unit 1, Custom Unit 2, Custom Unit 3												
Weighing Units, Approved Models	—	mg, g, ct		—	mg, g, ct	—	mg, g, ct	—	g, kg, ct	—	g, kg, ct	—	g, kg, ct
Pan Size (mm)	Ø 90 mm			Ø 130 mm			190 × 200 mm						
Calibration	All models feature external calibration. Models except for EX.../E feature AutoCal™ internal calibration												
Tare Range	To capacity by subtraction												
Power Requirements	AC Adapter Input: 100-240 VAC 0.6A 50-60 Hz												
Display Type	Full-color VGA graphic display, 4-wire resistive touch screen												
Display Size	145 mm (diagonal)												
Display Housing (W × H × D)	195 × 90 × 154 mm												
Base Housing (W × H × D)	230 × 350 × 393 mm						230 × 98 × 393 mm						
Communication	Standard RS232, 2x USB, Optional Ethernet												
Operating Temperature Range	10°C to 30°C												
Operating Humidity Range	15% to 80% at 30°C decreasing linearly to 50% at 40°C, non-condensing												
Storage Conditions	-10°C to 60°C at 10% to 90% relative humidity, non-condensing												
Net Weight	6.9 kg						4.3 kg			5 kg			
Shipping Weight	9.6 kg						6.8 kg			7.4 kg			
Shipping Dimensions	55 × 38.5 × 55.1 cm						55 × 38.5 × 29.1 cm						

Compliance

- **Metrology:** NIST Handbook 44 (NTEP CC 12-012), Measurement Canada Weights and Measures Regulations (AM-5847) (Class I, nmax 320000; Class II, nmax 42000; certified models only)
- **Product Safety:** IEC/EN 61010-1:2010; CAN/CSA-C22.2 No. 61010-1-12; UL Std. No. 61010-1 (3rd Edition)
- **Electromagnetic Compatibility:** IEC 61326-1; EN 61326-1:2006 (Class B); C-Tick; FCC Part 15 (Class A); ICES-003 (Class A)
- **Environment:** RoHS; WEEE

Accessories

Density Determination Kit.....	80253384	Tower Mount for Display**	30078082
Sinker glass for Density Determination Kit ...	83034024	Display Extension Cable (9 Meter / 27 Feet) ..	30078078
Full-featured Impact Printer SF40A	30064202	Display Extension Cable (2 Meter / 6.56 Feet). 83021083	
SF40A Paper roll (57,5mm 2pcs)	12120799	Draftshield Kit (0.01g, 0.1g, (non High Capacity models)	
SF40A Ink ribbon cassette	12120798	83021084
ION-100A – Ionizer	30095929	Security Device (Cable & Lock).....	80850000
RS232 Cable, PC 9 Pin	00410024	Security Device (Laptop Lock)	80850043
Cable, USB A to Mini USB, 1.8m Black	28120263	Rolling Feet Kit**.....	30041470
Cable, USB-RS232 Converter	30268619	Rechargeable Battery Pack**	30041295
Ethernet Kit.....	83021082	Auxiliary Display PAD7	80251396
Tower Mount for Display (non High Capacity models) ..		Terminal in-use cover	83033633
.....	83021102	Dust cover.....	30093334

*EC Type Approved models only **High Capacity models only

***The value for SRP is the standard deviation for n replicate weighings (n ≥ 10)

OHAUS Europe GmbH
Heuwinkelstrasse
8606 Naenikon
Switzerland

e-mail: ssc@ohaus.com
Tel: 0041 22 567 53 19
e-mail: tsc@ohaus.com
Tel: 0041 22 567 53 20

www.ohaus.com

OHAUS Corporation is an ISO
9001:2008 manufacturer

ISO 9001:2008
Registered Quality
Management System

